

**Construction of
Mountain Bike Trails
in Carron Valley Forest
Phase 1**

VOLUME 2

CONTRACT DETAILS

ENGINEER FOR THE WORKS

Jamie [REDACTED]
Carron Valley Development Group
c/o [REDACTED]

[REDACTED]
[REDACTED]
[REDACTED]

INDEX

	Page no.
Index page	1
Location plan	2
Scheme plan for the three trails to be constructed	3
Scheme plan to show quarry locations	4
Trail construction notes	5
Construction details	7
IMBA construction details	10
Construction photographs	15 - 23

LOCATION PLAN

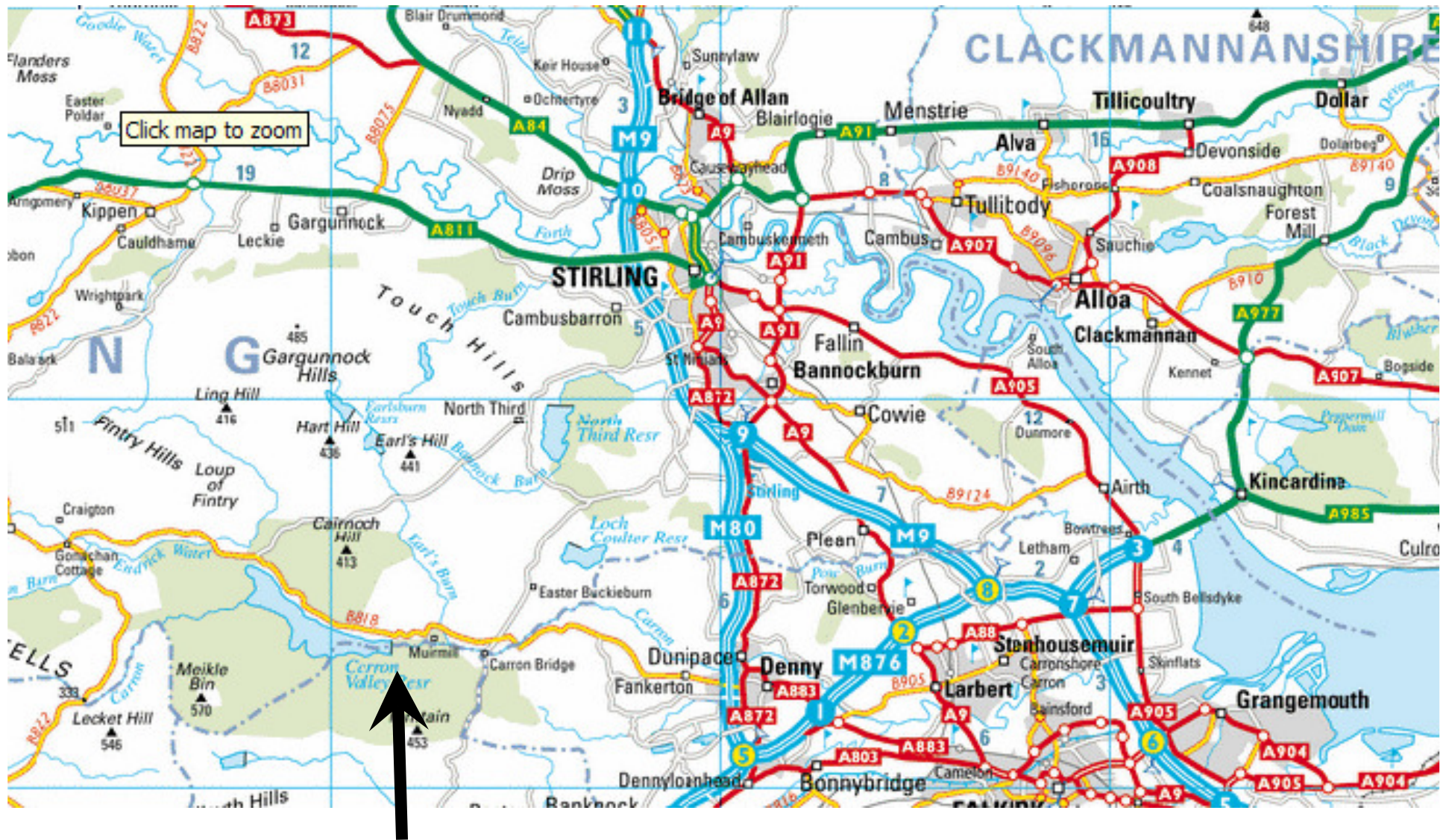

Carron Valley Forest

SCHEME PLAN SHOWING THE THREE TRAILS TO BE CONSTRUCTED



SCHEME PLAN TO SHOW QUARRY LOCATIONS



NOTES

It is envisaged that the only imported surfacing material will be the 25mm to dust whin stone, all other stone needed for construction is available within the three quarries shown on the above map. It should be noted however, that there is a large quantity of crushed stone available at the Upper Quarry which may be adequate for top dressing. The final decision on the suitability will be determined by the CVDG site representative.

TRAIL CONSTRUCTION NOTES

General

Modified Bench Cut – Form trail by cutting into side of slope, set aside some soil for re-dressing, side cast remainder of excavations (soil and subsoil), remove any additional soil from trail width, construct base of trail, grade out excavations, redress slope, surface top.

Tray and Fill – Excavate soil, grade into slope or re-use on overlay verges, fill with stone to construct base of trail, surface top.

Overlay – Construct base of trail on top of existing surface (normally boggy ground), Push in large stone if required, surface top, draw up soil to sides of trail or use soil from other parts of trail.

Chainage - The chainage (Ch) for each trail is expressed in metres and runs down the slope (from south to north on the scheme plan) i.e. chainage zero is at the top of each trail.

Upper Trail – Trail width 750mm

Ch 0 to 10 – Construct infill ramp.

Ch 10 to 190 – Tray and fill approx. 150mm.

Ch 190 to 214 – Modified bench cut.

Ch 214 – Place 600mm dia. pipe in stream bed, 6m long, form ramp with excavations and infill. Approximately 10m³ excavation and 10m³ imported fill.

Ch 214 to 248 – Overlay on geotextile after pushing larger infill into soft ground.

Ch 248 to 258 – Tray and fill with stone pitching approx 300mm.

Ch 258 to 437 – Modified bench cut.

Ch 437 to 494 – Minimal bench cut/tray and fill. Note :- 50m additional allowed for loop to approach waterfall.

Ch 494 to 521 – Modified bench cut.

Ch 521 to 610 – Strip soil, cut/fill to furrows.

Ch 610 – Place 600mm dia. pipe in stream bed 3m long.

Ch 610 to 659 – Tray and fill approx 300mm.

Ch 659 to 706 – Modified bench cut.

Ch 706 to 753 – Overlay on geotextile after pushing larger infill into soft ground.

Ch 753 to 784 – Modified bench cut.

Ch 784 to 789 – Tray and fill approx. 300mm. **End.**

Middle Trail – Trail width 750mm

Ch 0 to 10 – Tray and fill approx. 150mm.

Ch 10 to 22 – Modified bench cut.

Ch 22 to 29 – Tray and fill approx. 150mm.

Ch 29 – Bridge.

Ch 29 to 132 – Minimal bench cut/tray and fill approx. 150mm to Ch 80 and 300mm thereafter.

Ch 84 – Place 300mm dia. pipe in stream bed 3m long.

Ch 132 – Place 450mm dia. pipe in stream bed 3m long.

Ch 132 to 179 – Tray and fill approx. 300mm.

Ch 135 – Place 300mm dia. pipe in stream bed 3m long.

Ch 179 to 201 – Modified bench cut.

Ch 201 to 213 – Tray and fill approx. 300mm.

Ch 211 – Place 150mm dia. pipe in ditch 3m long.

Ch 213 to 312 – Modified bench cut.

Ch 312 to 547 – Mix of Modified bench cut and tray and fill approx 150mm.

Ch 416 – Bridge.

Ch 547 – Bridge.

Ch 547 to 740 – Strip soil, cut/fill to furrows.

Ch 547 to 740 – Also place 150mm dia. pipe in furrows at various locations. 12 x 3m long.

Ch 740 to 786 – Modified bench cut.

Ch 786 to 793 – Tray and fill approx. 150mm.

Ch 793 to 830 – Modified bench cut.

Ch 830 to 843 – Tray and fill approx. 150mm. **End.**

Lower Trail – Trail width 1200mm (Laid on Geotextile)

Ch 0 to 209 – Overlay 150mm deep after cut/fill grading.
Ch 3 – 2 x 150mm dia. pipes 3m long.
Ch 100 – Table top.
Ch 209 – Bermed corner approx. 1m high, 10m long.
Ch 209 to 299 – Modified bench cut.
Ch 255 – Table top.
Ch 255 – Large rock pushed into soft area, 2m wide x 1m deep.
Ch 255 – Bermed corner approx. 1m high, 10m long.
Ch 255 to 307 – Overlay.
Ch 307 to 393 – Overlay 300mm deep after cut/fill grading.
Ch 352 – Table top.
Ch 375 to 393 – Clean out ditch.
Ch 393 – Place 300mm dia. pipe in ditch 3m long.
Ch 393 to 483 – Modified bench cut.
Ch 483 to 559 – Minimal bench cut/tray and fill approx. 150mm.
Ch 559 to 580 – Overlay on geotextile after pushing larger infill into soft ground.
Ch 573 – Place 300mm dia. pipe in stream bed 3m long.
Ch 580 to 626 – Modified bench cut.
Ch 626 to 664 – Tray and fill approx. 150mm.
Ch 635 – Place 600mm dia. pipe in stream bed 4m long.
Ch 635 – Infill over pipe for 6m at 500mm deep.
Ch 483 to 760 – Table top to be constructed within this section.
Ch 664 to 695 – Tray and fill approx. 150mm.
Ch 695 to 760 – Modified bench cut.
Ch 760 to 855 – Overlay/tray and fill approx. 200mm deep.
Ch 846 – Table top.
Ch 855 to 1024 – Overlay 500mm deep. Allow double the length for loops in trail.
Ch 855 to 1024 – Table top x 4 to be constructed within this section.
Ch 1024 – Place 600mm dia. pipe in stream bed 4m long.
Ch 1024 to 1050 – Overlay 300mm deep. **End.**

CONSTRUCTION DETAILS

MODIFIED BENCH CUT

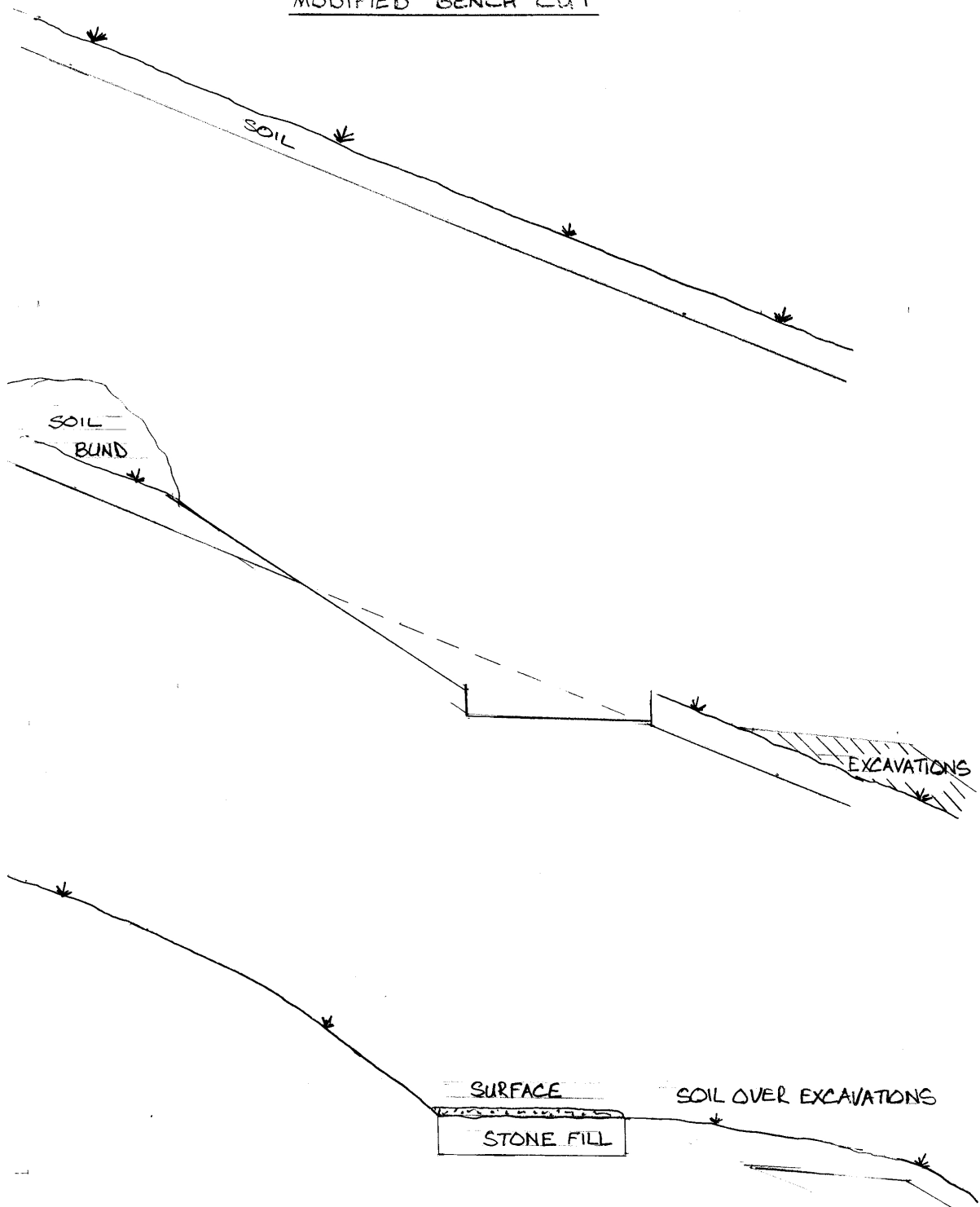

TRAY AND FILL

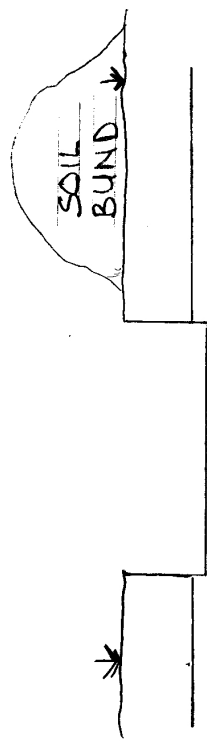
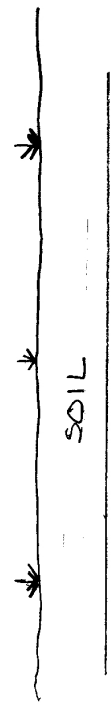

DRESS OFF SOIL
TO VERGES, OR USE
IN OVERLAY AREAS

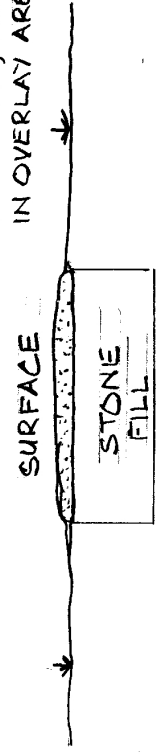

OVERLAY

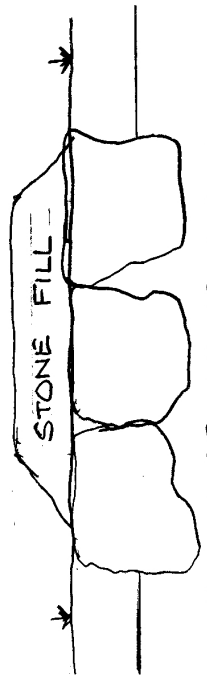

LARGE STONE PUSHED
INTO SOFTER GROUND
WHERE REQUIRED

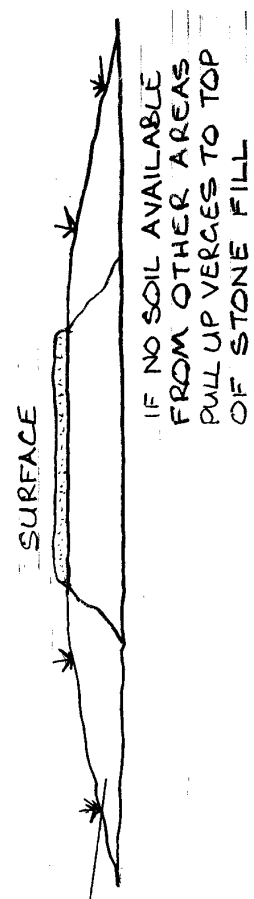

IF NO SOIL AVAILABLE
FROM OTHER AREAS
PULL UP VERGES TO TOP
OF STONE FILL

TABLE TOP

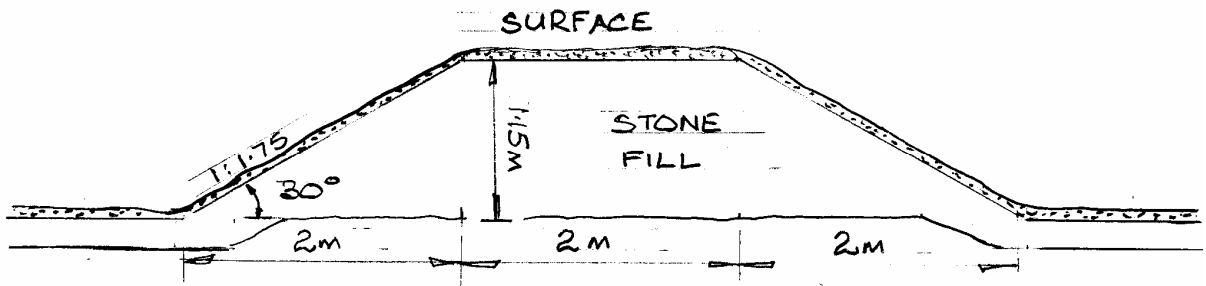

LONG SECTION

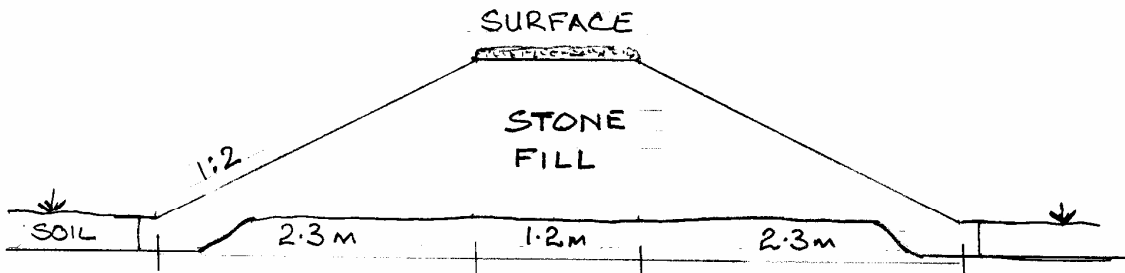

CROSS SECTION

BERMED CORNER

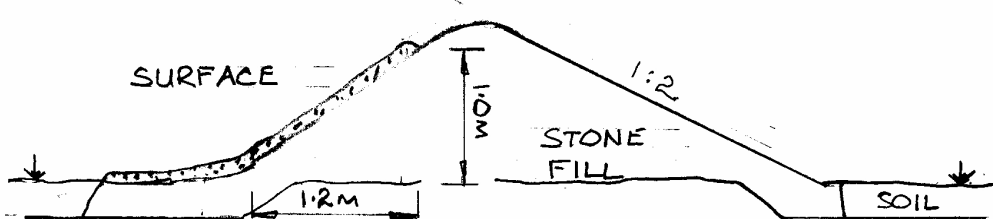

TYPICAL CROSS SECTION

IMBA CONSTRUCTION DETAILS

Rolling Contour Trail

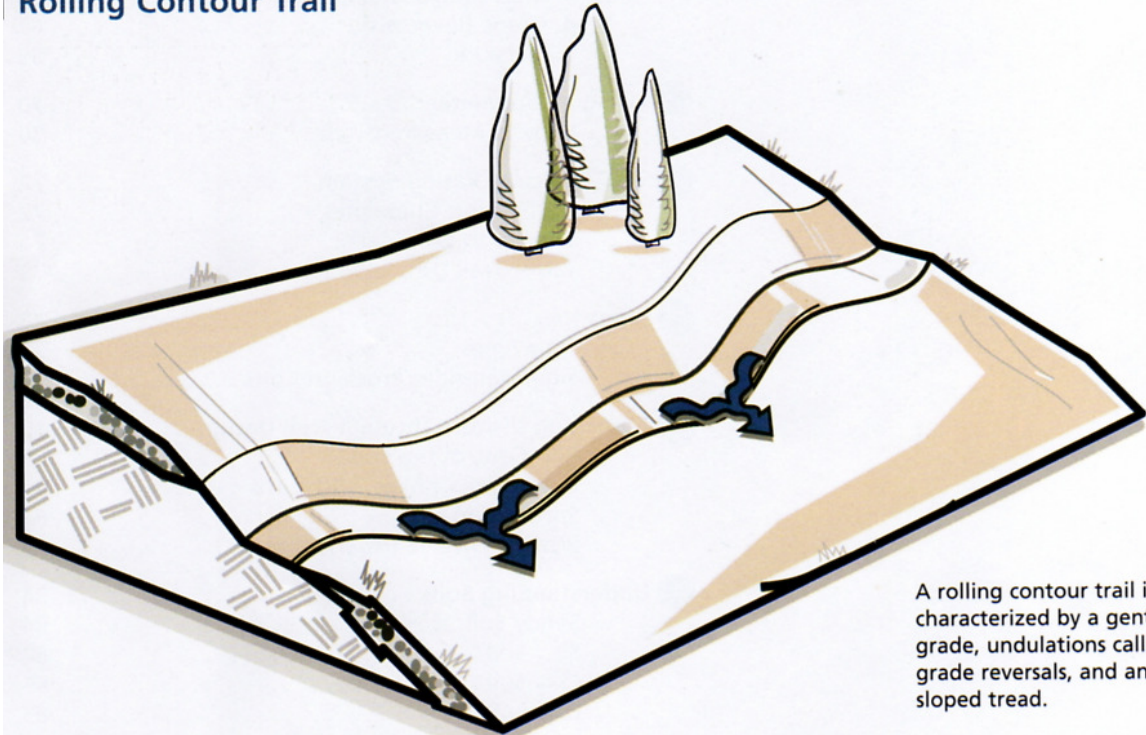

A rolling contour trail is characterized by a gentle grade, undulations called grade reversals, and an out-sloped tread.

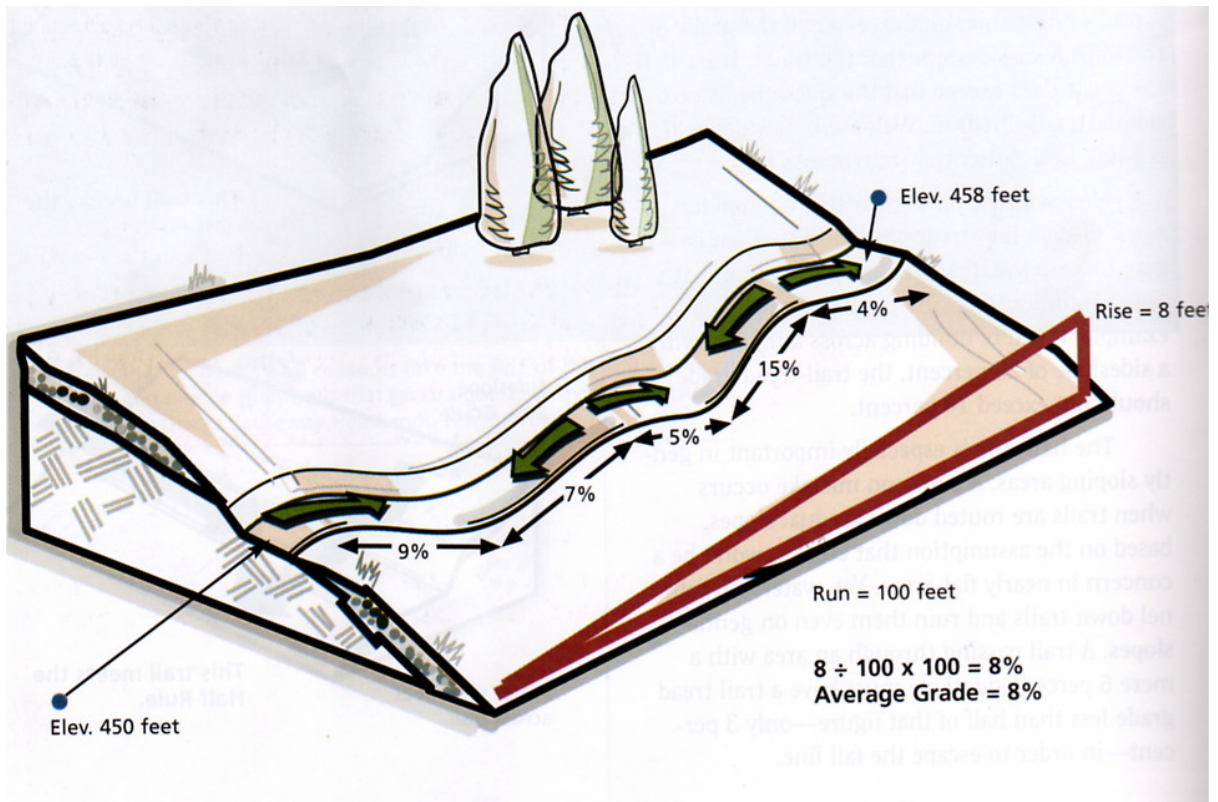

Typical Cross Section of Trail

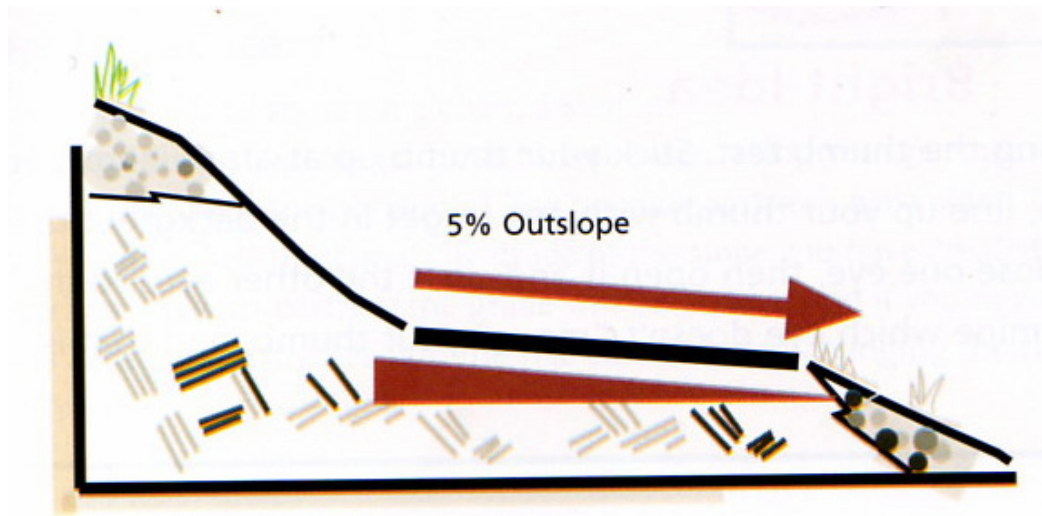

Note

The final trail surface should be constructed wherever possible to shed water from the trail.

Stone Pitching

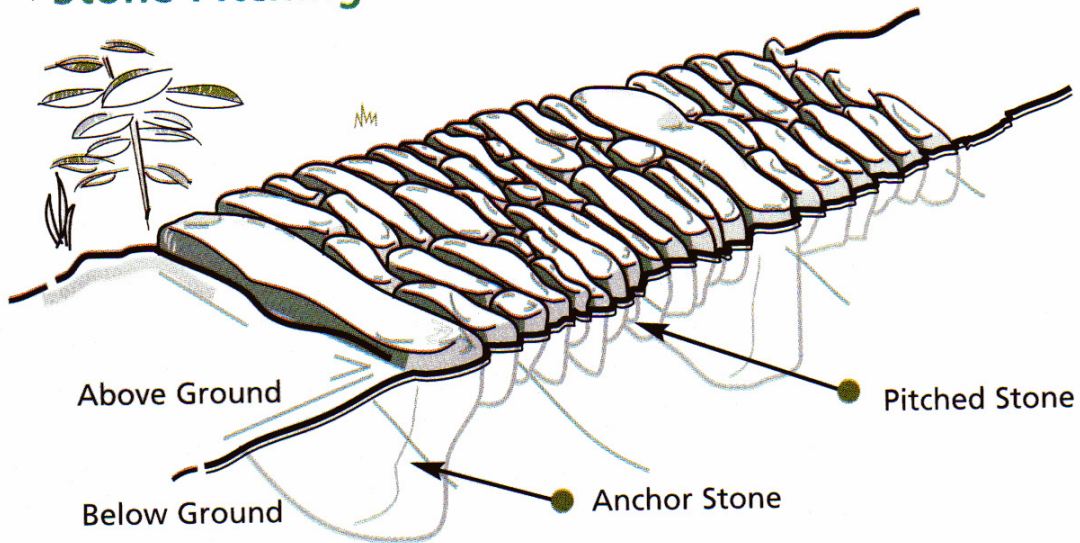

Raised Tread Construction

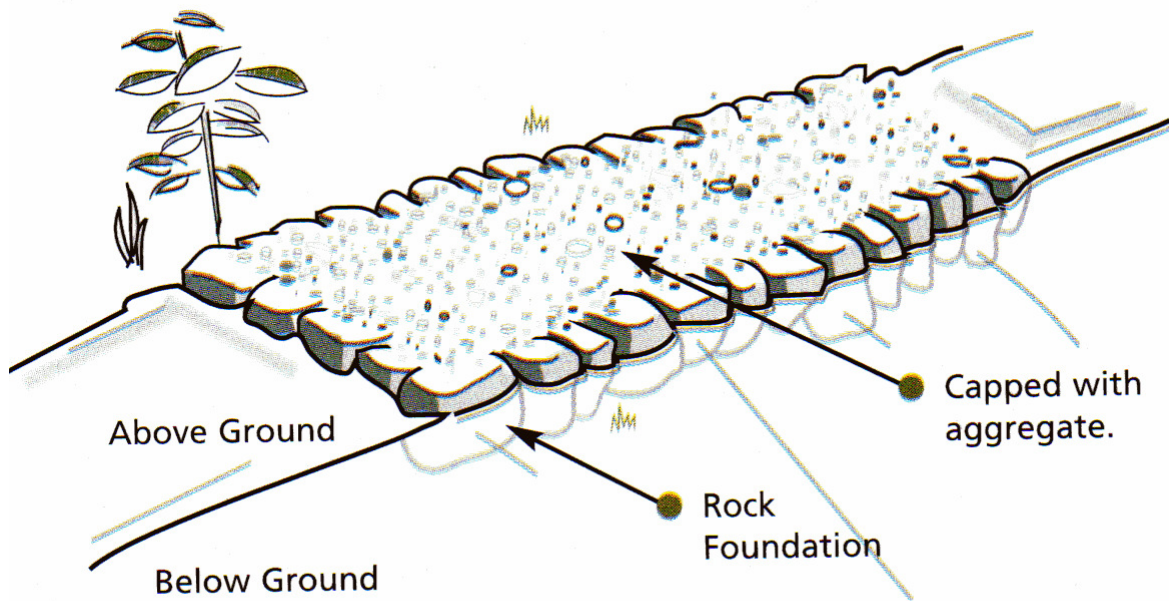

Note

The raised tread construction is the typical detail to be adopted for crossing areas of wet or boggy ground.

Proper Drainage Crossing

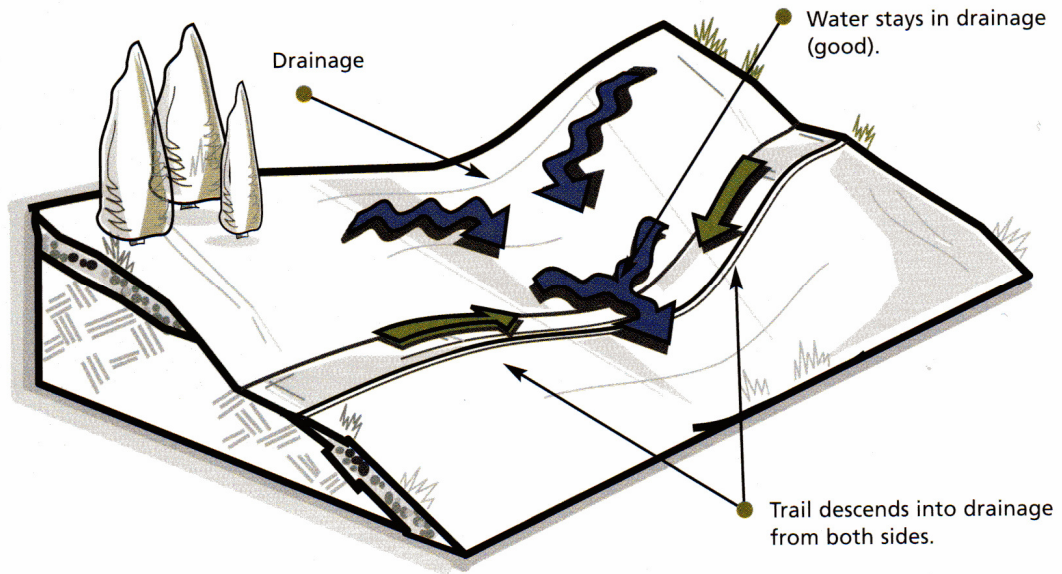

Improper Drainage Crossing

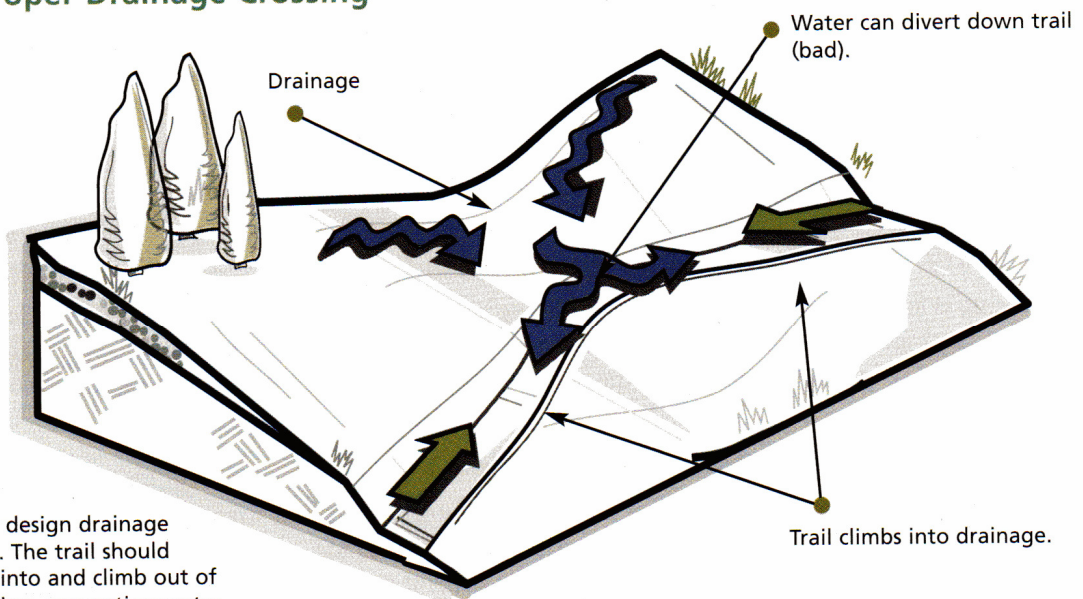

Carefully design drainage crossings. The trail should descend into and climb out of the crossing, preventing water from flowing down the trail.

Ladder Bridge

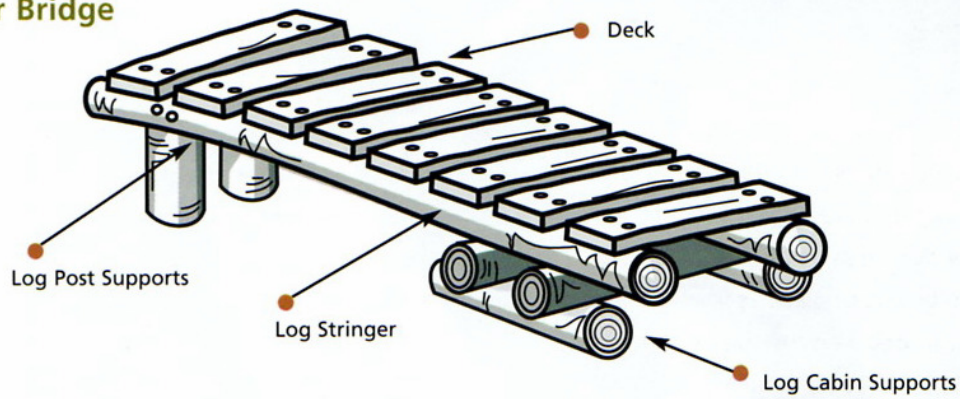

May be constructed from hand-prepared logs or dimensional lumber.

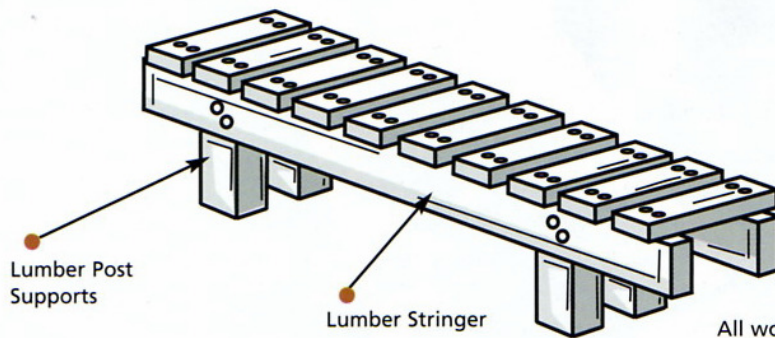

All wooden features should be designed and constructed with the assistance of an experienced carpenter.

Note

The bridge deck should have an overall free running width of 800mm with an anti-slip surface applied.

All timber used in the construction to be pressure treated.

The deck must be anchored to a suitable foundation.

CONSTRUCTION PHOTOGRAPHS



This photograph demonstrates a typical finished trail and what is trying to be achieved on the project at Carron Valley Forest.



A typical example of a bermed corner.



A typical stone fill example prior to the surface coat being applied i.e. the finer material.



An example of a finished stone pitched surface.



Another example of a bermed corner.



A typical example of a piped culvert with a headwall built using dry bonded stone and turfed to blend in.



An example of a stone built bridge which is a possible alternative to the timber ladder bridge design, however, this would require to be approved by the CVDG site representative prior to construction.



An example of where the bench cut has been minimised by increasing the angle of the side slope, this should only be carried out with the prior agreement of the CVDG site representative. At all times the stability of the side slope has to be maintained.



An example of where natural features have been incorporated into the trail construction, this principle should be adopted on the Carron Valley project where appropriate.